



**RX8247**

**Ergo™ Long Flush Precision Cut  
45° Angle Tapered Head Oblique  
Cutter 0.2 mm-1 mm**







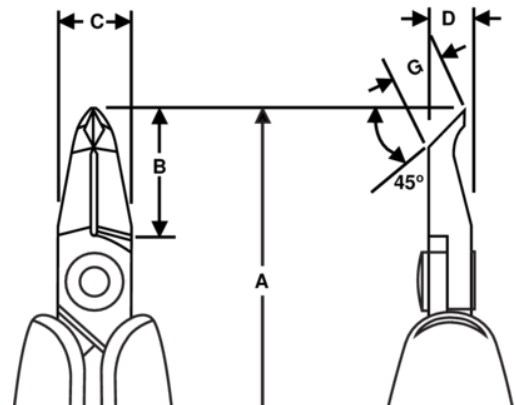

## PRODUCT DETAILS

- Ideal for assembly work where accessibility is a consideration
- Developed according to the ERGO® process for a comfortable and effective grip in all situations
- Material: High performance alloy steel
- Precision induction hardened edges 63–65 HRC
- ESD safe handles in 2-component synthetic material
- Precision screw joint that minimizes friction and maximizes alignment of cutting edges
- Biospring® reduces tension throughout the working cycle of the tool and can be adjusted in three different positions
- Cutting capacity is listed for solid copper wire
- Burnished finish



PRODUCT ATTRIBUTES

Product: **RX8247**

	Angle 45°		S	<b>A</b>	143.0 mm
<b>A</b>	5.63 in	<b>B</b>	18 mm	<b>B</b>	0.71 in
<b>C</b>	10 mm	<b>C</b>	0.39 in	<b>D</b>	6 mm
<b>D</b>	0.24 inch	<b>G</b>	6.7 mm	<b>G</b>	0.26 in
	0.2-1.0 mm		0.01-0.04 in		Flush
	72 g	<b>Ω</b>	Dissipative		