



## RX 8136-RX 8168 ERGO™ Precision Diagonal Cutters with Tapered & Relieved Head







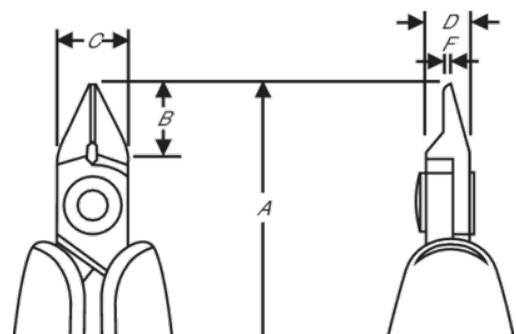

### PRODUCT DETAILS

- Precision extra tapered & relieved head diagonal cutters developed according to the scientific ERGO™ process
- Extra Tapered & relieved head
- ERGO™ handles with two-component combination, thermoplastic surface, for comfortable grip, on tough polypropylene core for rigidity
- Flush & ultra-flush
- The cutting capacity that is given is for copper wire
- Cutting capacity: 0.1 mm-0.8 mm
- High performance alloyed steel
- Burnished finish
- Numerically controlled machine grinding guarantees edge angle accuracy & contact, increases the tool's reliability & consistency
- Precision induction-hardened edges 63-65 HRC
- Screw joint minimises friction & maximises alignment of cutting edges
- ESD safe handles in two-component synthetic material
- Bio spring limits the tension throughout the working cycle of the tool & can be adjusted to 3 different positions or removed
- Ideal for use in confined spaces & for rework thanks to the thinner tip head









PRODUCT ATTRIBUTES







**Product: RX8136**

	Tapered & Relieved		XS		Micro-Bevel®
	0.1-0.8 mm		0.004-0.03 in	<b>A</b>	108 mm
<b>A</b>	4.25 in	<b>B</b>	8 mm	<b>B</b>	0.31 in
<b>C</b>	8 mm	<b>C</b>	0.31 in	<b>D</b>	5 mm
<b>D</b>	0.2 inch	<b>F</b>	0.8 mm	<b>F</b>	0.03 in
	66 g		Dissipative		







**Product: RX 8137**

	Tapered & Relieved		XS		Flush
	0.1-0.8 mm		0.004-0.03 in	<b>A</b>	108 mm
<b>A</b>	4.25 in	<b>B</b>	8 mm	<b>B</b>	0.31 in
<b>C</b>	8 mm	<b>C</b>	0.31 in	<b>D</b>	5 mm
<b>D</b>	0.2 inch	<b>F</b>	0.8 mm	<b>F</b>	0.03 in
	66 g		Dissipative		







**Product: RX8138**

	Tapered & Relieved		XS		Ultra-Flush®
	0.1-0.5 mm		0.004-0.02 in	<b>A</b>	108 mm
<b>A</b>	4.25 in	<b>B</b>	8 mm	<b>B</b>	0.31 in
<b>C</b>	8 mm	<b>C</b>	0.31 in	<b>D</b>	5 mm
<b>D</b>	0.2 inch	<b>F</b>	0.8 mm	<b>F</b>	0.03 in
	66 g		Dissipative		







**Product: RX 8146**

	Tapered & Relieved		S		Micro-Bevel®
	0.2-1.0 mm		0.01-0.04 in	<b>A</b>	135.5 mm
<b>A</b>	5.25 in	<b>B</b>	10.5 mm	<b>B</b>	0.41 in
<b>C</b>	10 mm	<b>C</b>	0.39 in	<b>D</b>	6 mm
<b>D</b>	0.24 inch	<b>F</b>	0.8 mm	<b>F</b>	0.03 in
	68 g		Dissipative		







**Product: RX 8147**

	Tapered & Relieved		S		Flush
	0.1-1.0 mm		0.00-0.04 in	<b>A</b>	135.5 mm
<b>A</b>	5.25 in	<b>B</b>	10.5 mm	<b>B</b>	0.41 in
<b>C</b>	10 mm	<b>C</b>	0.39 in	<b>D</b>	6 mm
<b>D</b>	0.24 inch	<b>F</b>	0.8 mm	<b>F</b>	0.03 in
	68 g		Dissipative		







**Product: RX 8148**

	Tapered & Relieved		S		Ultra-Flush®
	0.1-0.8 mm		0.00-0.03 in	<b>A</b>	135.5 mm
<b>A</b>	5.25 in	<b>B</b>	10.5 mm	<b>B</b>	0.41 in
<b>C</b>	10 mm	<b>C</b>	0.39 in	<b>D</b>	6 mm
<b>D</b>	0.24 inch	<b>F</b>	0.8 mm	<b>F</b>	0.03 in
	68 g		Dissipative		







**Product: RX 8156**

	Tapered & Relieved		M		Micro-Bevel®
	0.3-1.25 mm		0.01-0.05 in	<b>A</b>	138 mm
<b>A</b>	5.30 in	<b>B</b>	13 mm	<b>B</b>	0.51 in
<b>C</b>	12.5 mm	<b>C</b>	0.49 in	<b>D</b>	6 mm
<b>D</b>	0.24 inch	<b>F</b>	1.2 mm	<b>F</b>	0.05 in
	70 g		Dissipative		







**Product: RX 8157**

	Tapered & Relieved		M		Flush
	0.2-1.25 mm		0.01-0.05 in	<b>A</b>	138 mm
<b>A</b>	5.30 in	<b>B</b>	13 mm	<b>B</b>	0.51 in
<b>C</b>	12.5 mm	<b>C</b>	0.49 in	<b>D</b>	6 mm
<b>D</b>	0.24 inch	<b>F</b>	1.2 mm	<b>F</b>	0.05 in
	70 g		Dissipative		







**Product: RX 8158**

	Tapered & Relieved		M		Ultra-Flush®
	0.2-1.0 mm		0.01-0.04 in	<b>A</b>	138 mm
<b>A</b>	5.30 in	<b>B</b>	13 mm	<b>B</b>	0.51 in
<b>C</b>	12.5 mm	<b>C</b>	0.49 in	<b>D</b>	6 mm
<b>D</b>	0.24 inch	<b>F</b>	1.2 mm	<b>F</b>	0.05 in
	70 g		Dissipative		







**Product: RX8166**

	Tapered & Relieved		L		Micro-Bevel®
	0.4-1.5 mm		0.02-0.06 in	<b>A</b>	147 mm
<b>A</b>	5.80 in	<b>B</b>	16 mm	<b>B</b>	0.63 in
<b>C</b>	16 mm	<b>C</b>	0.63 in	<b>D</b>	8 mm
<b>D</b>	0.31 inch	<b>F</b>	1.6 mm	<b>F</b>	0.06 in
	139 g		Dissipative		

**Product: RX 8167**

	Tapered & Relieved		L		Flush
	0.3-1.5 mm		0.01-0.06 in	<b>A</b>	147 mm
<b>A</b>	5.80 in	<b>B</b>	16 mm	<b>B</b>	0.63 in
<b>C</b>	16 mm	<b>C</b>	0.63 in	<b>D</b>	8 mm
<b>D</b>	0.31 inch	<b>F</b>	1.6 mm	<b>F</b>	0.06 in
	139 g		Dissipative		

**Product: RX 8168**

	Tapered & Relieved		L		Ultra-Flush®
	0.3-1.25 mm		0.01-0.05 in	<b>A</b>	147 mm
<b>A</b>	5.80 in	<b>B</b>	16 mm	<b>B</b>	0.63 in
<b>C</b>	16 mm	<b>C</b>	0.63 in	<b>D</b>	8 mm
<b>D</b>	0.31 inch	<b>F</b>	1.6 mm	<b>F</b>	0.06 in
	139 g		Dissipative		